

PCME VIEW 160

PROSCATTER™
INSIDE

Particulate

Measurement

System

Particulate
CEM

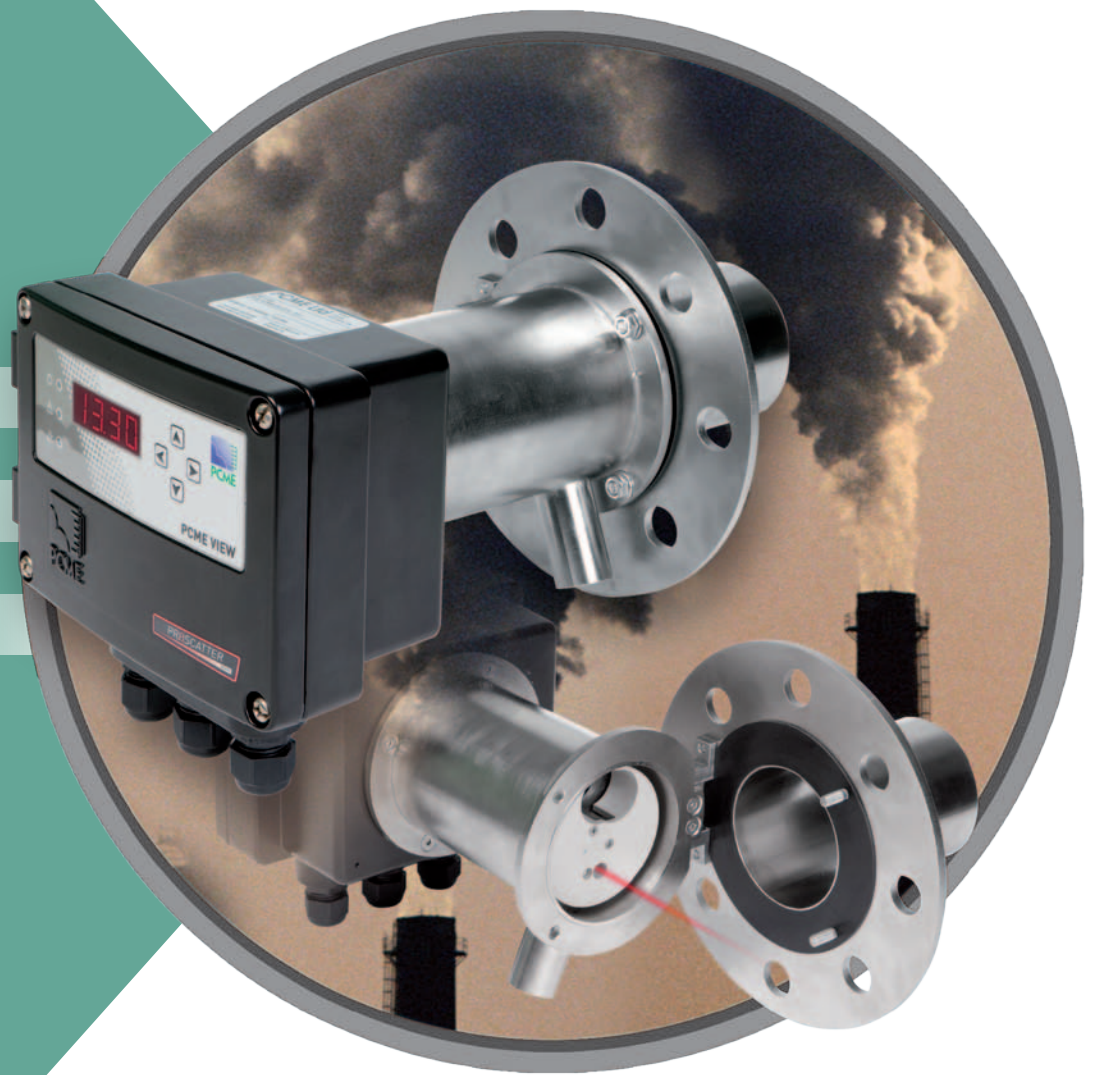

- Optimised for monitoring particulate in stack sizes 2-10m
- Convenient, single point connection to stack without need for separate light absorber (beam dump) on far side of stack
- *ProScatter™* Backscatter technology increases depth of measurement volume into the stack
- Improved dust resolution (<math><10 \text{ mg/m}^3</math>) and higher reliability compared to Opacity
- Automatic zero and span check features for high quality assurance

technology/applications

System Description

The **PCME VIEW 160** is suitable for measuring particulate emissions in medium to large diameter stacks (2-10m) on industrial and combustion processes. It provides a reliable alternative to traditional opacity instruments for monitoring both abatement plant failure and particulate concentrations. The analyser can also be used to measure dust concentrations below $10\text{mg}/\text{m}^3$ making it suitable for the highly abated emissions found after bagfilters as well as levels up to $300\text{mg}/\text{m}^3$. It is unaffected by changes in flue gas velocity associated with variable speed fans or plant load changes.

The **PCME VIEW 160** is conveniently mounted on one side of the stack and requires no light absorber or beam dump on the opposite side of the stack. The sensor itself is non-intrusive in the stack meaning that all critical optical components can be kept contamination free by simple air purging (instrument air or blower option).

The **PCME VIEW 160** is provided as a sensor complete with its own power supply, display, keypad and user interface providing the convenience of local set-up and display.



Reliability and Contamination Resistance

The instrument is designed for long term reliable operation without the need for regular operator inspection or intervention. Any stray scattered light from the stack wall which would be the source of an instrument offset is eliminated by a 'field of view' which is optimised to measure well into the stack while being insensitive to signal from the far stack wall. The effects of ambient light are eliminated using a modulated laser source. Optical components are maintained clean by the use of an air purge which protects the optical surfaces from making direct contact with stack gas or particulate.

Principles of Operation

The **PCME VIEW 160** measures the amount of light scattered back from particles in the stack illuminated by a modulated laser. The instrument's *ProScatter*TM Backscatter technology means that the 'telescoped' detector field of view is critically controlled to eliminate stray scattering from the far inside stack wall. The low angle of measurement increases the effective penetration of the measurement volume into the stack (typically at least half way across stack) compared to 'higher angle' back scatter instruments.

The instrument response is proportional to dust concentration for a given particle type and size and may be calibrated in mg/m^3 by comparison to the results of a standard reference test (iso-kinetic test).

*ProScatter*TM Backscatter technology is able to resolve dust levels to below $10\text{mg}/\text{m}^3$ meaning that it may be installed in applications with emissions well below the resolution limit of traditional opacity instruments.

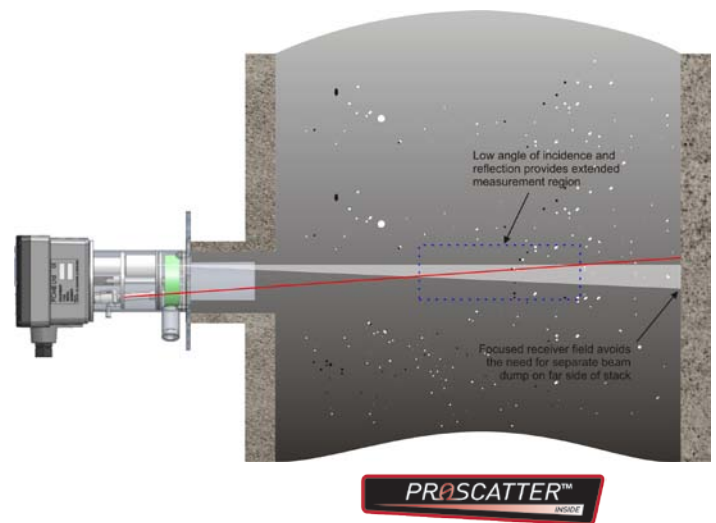

Self-checks for Compliance Measurement

The instrument is provided with a convenient hinged enclosure which permits access to the optical surface to check the cleanliness, linearity and functionality of the scattering system.

The instrument includes an automatic zero check. The automatic self check inserts a span element in which a scattering surrogate is automatically rotated into the laser path and the resultant scattered light signal is measured by the detector. Any deterioration caused by laser aging, instrument drift or optics contamination is detected automatically, in effect providing both a span and contamination check result. The instrument can be manually audited with a set of independent reference materials (option) as part of periodic functionality and linearity tests.

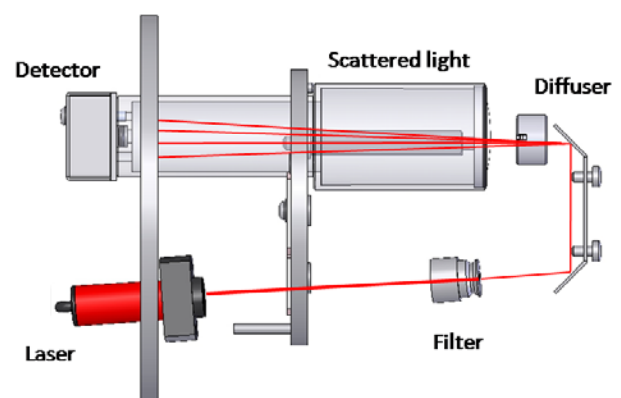

product features

Typical Use and Applications

- Continuous PM measurement and emission limit monitoring in power plant/boiler applications
- Filter Leak and Bag Leak detection after bagfilters on large stack (<2m) / boiler applications
- Alternative to opacity in power plant and combustion applications where emissions to be reported in mg/m³
- Monitoring performance of filter abatement plant operation in metals, minerals and chemical plant where stack size greater than 2m

Application note: for low dust (incineration) and/or smaller bagfilter applications, PCME's range of *ElectroDynamic*TM Probe Electrification and *ProScatter*TM Forward Scatter instruments should be considered since their application range covers both dust concentrations of 0.1mg/m³ - 300mg/m³ and stack sizes of 0.5m - 4m.

Application Performance

| | |
|----------------------------------|--|
| Dust measurement range | 10-300mg/m ³ |
| Stack diameter | 2 - 10m |
| Maximum stack temperature | 250°C (standard) 400°C option |
| Recommended inspection frequency | 3 months |
| Air purge requirement: | PCME supplied blower or suitably conditioned instrument air |
| Flue gas restrictions: | Not for use if flue gas below dew point or for applications containing water droplets (wet scrubber) |
| Ambient Air Temperature | -10°C to +55°C |
| Stack connection | Hole pattern to suit DN80 P10/PN16 or 3" 150lb ANSI (hole ID at least 88mm) |
| Enclosure Size (mm) | 220 W x 123 H x 80 D |
| Power Supply | 100 to 240 VAC (50/60Hz), 1A |



Production Specifications

| | |
|--------------------|---|
| Enclosure rating | IP65 |
| Power requirements | 100-240VAC 50/60Hz or 24VDC |
| Outputs (standard) | Isolated 4-20mA 2 independent alarm relays (SPST 1A@24VDC) |
| Outputs (optional) | RS232 Modbus RTU RS485 Modbus RTU Ethernet (via NetBox) |
| Inputs | Plant stop signal marker for start of bag cleaning sequence |
| External LED x3 | Power/sensor OK Warning and limit alarm Self check status |
| User set up | Via internal keypad and display (standard) Via external keypad and externally viewable display as option Via PC-ME Tools (PC software): requires RS232/485 connection |

Bag Pulse Display Module

The **PCME VIEW 160** may be upgraded to provide Leak Locate capability by adding the optional Bag Pulse Display module. This enables plant operators to locate the position of failing bag rows in the dust collector, hence reducing bag replacement costs and minimising time diagnosing dust collector faults.

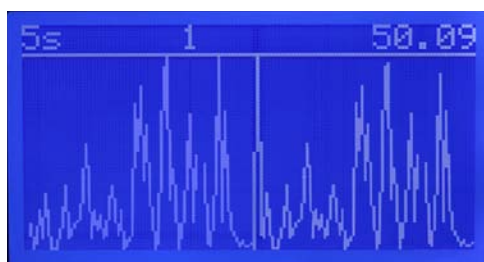

Pulse Display permits failing bag rows to be identified during bag cleaning



specifications

Dimensions

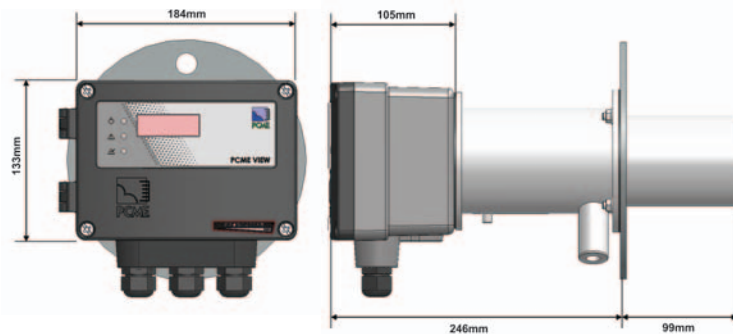

(shown with optional external display)

Flange

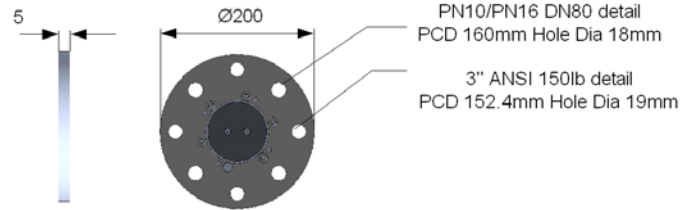

Order Codes

PCME View 160 – 1 2 / A B C D E F G

Measurement Options

| | | | | |
|---|-------------------|----------------------------|--------------------|--------------|
| 1 | Stack Temperature | Up to 250°C Up to 400°C | Standard Option | 250C 400C |
| 2 | Stack Diameter | 2-4m 4-10m | Standard Option | 2D 4D |

Sensor Features

| | | | | |
|---|-------------------------------|--|--------------------|------------|
| A | Automatic Self Checks | Auto Zero and Span | Standard | SPAN |
| B | Power Options | 100-240VAC 24VDC | No Cost Option | AC 24DC |
| C | RS485 Data Output | Not included RS485 included | Standard Option | 0 485 |
| D | RS232 Data Output | Not included RS232 included | Standard Option | 0 232 |
| E | External Connectors for RS232 | Internal connector External connector | Standard Option | 0 FLY |
| F | Keypad | Internal keypad External keypad | Standard Option | IK EK |
| G | Display | Internal Externally viewable | Standard Option | ID ED |

Accessories

| | | | |
|--------------------------|----------------------|---------------------------------|----------|
| Air Purge Blower | Air purging required | PCME Blower recommended | ACCAIR-B |
| Fast Ethernet | Optional accessory | 100Mbps/sec data transfer speed | NETBOX |
| Bag Pulse Display Module | Optional accessory | | BPDM |

Example: SEN 160 1 2 - A B C D E F G
250C 4D - SPAN AC 485 0 0 IK ED

About PCME Ltd

As a progressive environmental Company, PCME specialises in particulate measurement for industrial processes. With a worldwide reputation for reliability, innovation and technological excellence, the Company produces equipment for concentration and mass monitoring for regulatory, environmental and process control requirements. A dedicated team of qualified application and sales engineers is always on hand and should be consulted in the selection and usage of the most suitable equipment for any particulate application.

Contact your national or area sales and service office



PCME Ltd
 Clearview Building
 60 Edison Road
 St Ives Cambs UK
 PE27 3GH
 Tel: +44 (0)1480 468200
 Fax: +44 (0)1480 463400
 E-mail: contact@pcme.com
www.pcme.com